

THALES

Building a future we can all trust

NTN-TN Convergence for 5G/6G Networks – Use Cases & Challenges

Thematic days on NTN communications
(Organised by the CNRS GDRs RSD & ISIS)
19th-20th of October 2023

Dorin Panaitopol
THALES SIX GTS FRANCE

www.thalesgroup.com

THALES GROUP OPEN



5G NR NTN in Release-17 (5G NR Direct Smartphone Access)

Key Issue: Doppler resulted from Satellite high speed.

Doppler and Timing Advance (TA) Pre-compensation

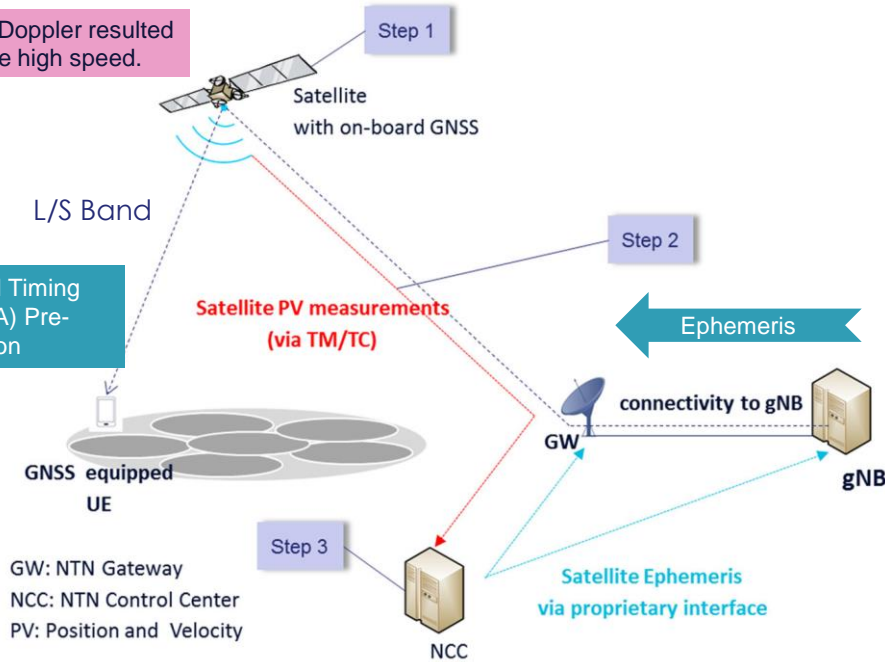

General Hypothesis:

- UE (User Equipment) with GNSS;
- Ephemeris data send through satellite to UE (broadcast SIB19);

UE is using GNSS and Ephemeris data to pre-compensate Doppler and Timing Advance;

Transparent satellite configuration with:

- Earth Fixed or Earth Moving Cells;

Considered constellation types:

- LEO@600km (worst case, higher Doppler);
- LEO@1200km;
- GEO.

Intermediate constellations are also possible.

5G NR Satellite NTN integration with 5G NR TN – Short View

Rel-17: Ended (March 2023 from RAN4 point of view)

- **Transparent Satellite;**
- NTN UE is a **Smartphone** in **L/S Bands**.

Rel-18: On-going work (TBC mid-2024?)

- **Transparent Satellite;**
- NTN UE is a **VSAT** operating in **Ka-band**.

Rel-19: TBC end-2025?

- **Regenerative Satellite?**
- Other bands: **Ku, Q/V..?**
- Other **FR1-NTN UE types: HPUE?**
- NTN UE **without GNSS?**

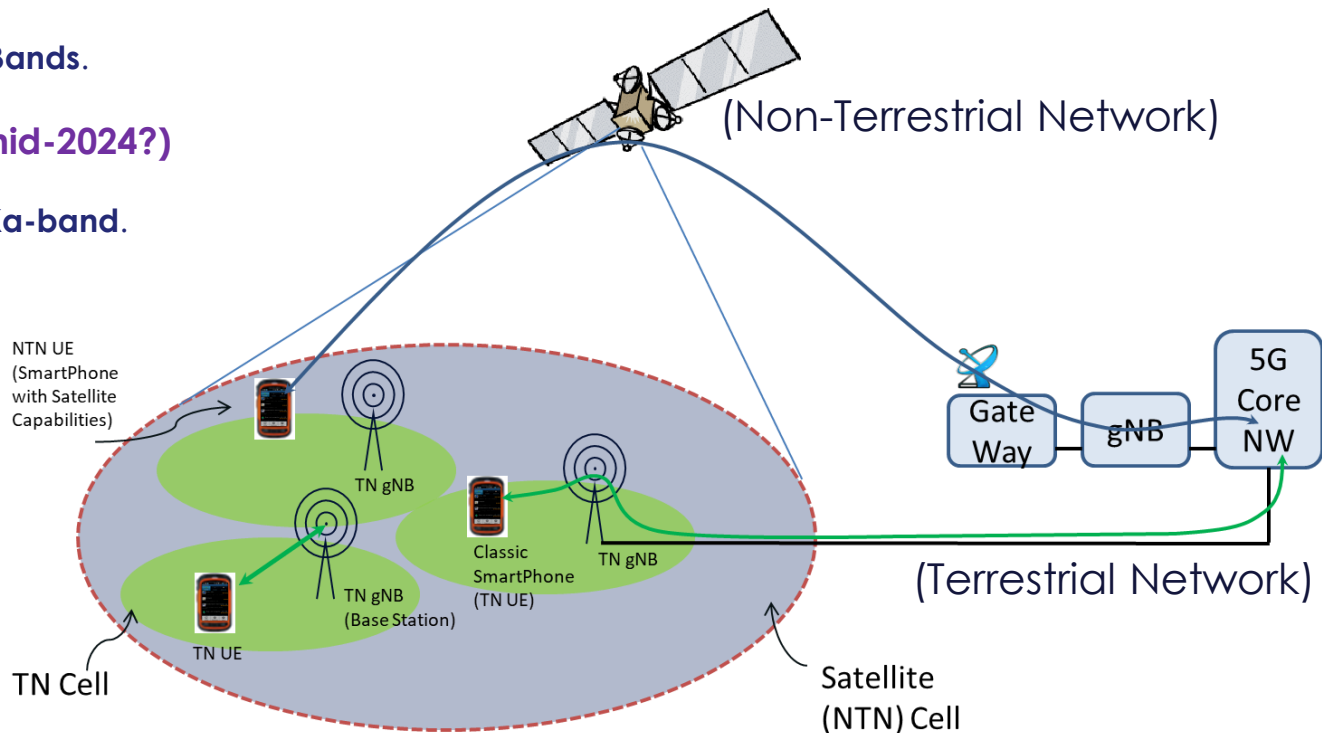

3GPP NTN standard: Tentative Roadmap for 5G & 6G

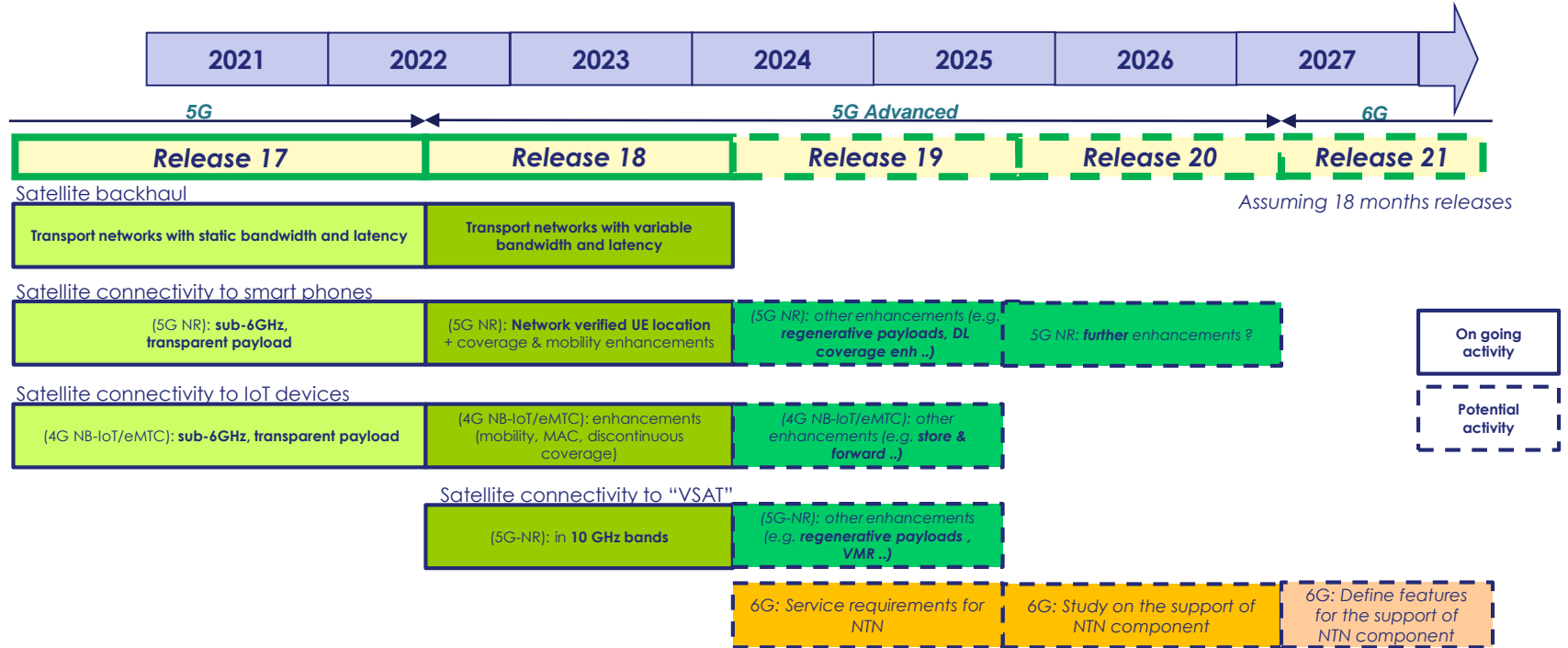

TN = Terrestrial Network
 NTN = Non Terrestrial Networks (Satellite, HAPS)
 VMR: Vehicle Mounted Relay
 IAB: Integrated Access and Backhaul

Ce document ne peut être reproduit, modifié, adapté, publié, traduit, d'une quelconque façon, en tout ou partie, ni divulgué à un tiers sans l'accord préalable et écrit de THALES - © 2021 THALES, Tous Droits réservés.

Focus on 6G TN & 6G NTN: 3GPP and ITU-R

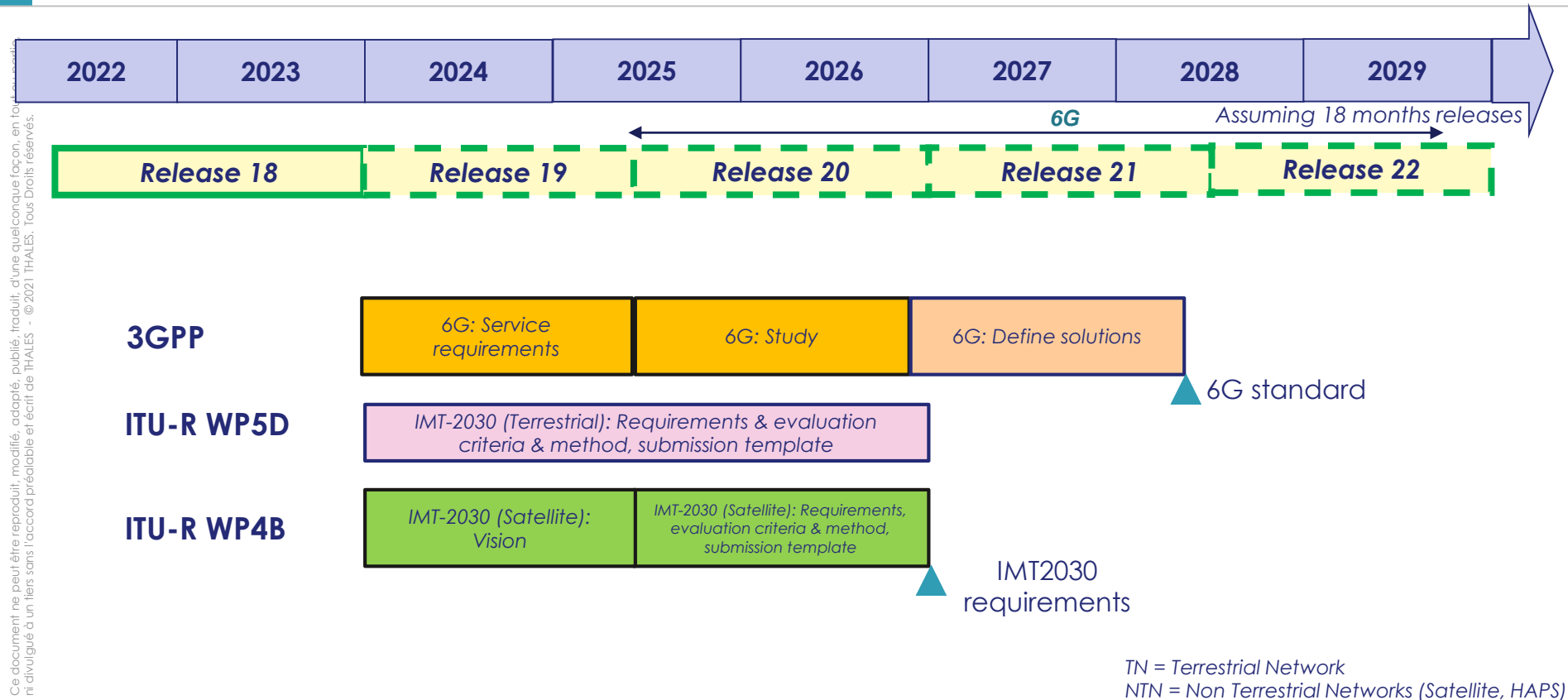

Ce document ne peut être reproduit, modifié, adapté, publié, traduit, d'une quelconque façon, en tout ou en partie, sans l'accord préalable et écrit de THALES - © 2021 THALES, Tous Droits réservés.

5G NR NTN Context in 3GPP RAN4 Work Group – RF & Radio Resource Management

NTN-TN adjacent band coexistence analysis (examples Rel-17):

- n256 (FDD NTN) with n1 (FDD TN) – top figure
- n256 (FDD NTN) with n34 (TDD TN) – bottom figure

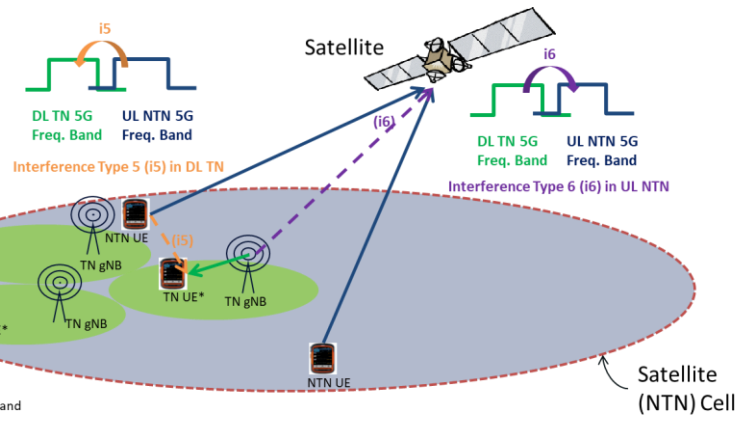

S-band NTN-TN adjacent band coexistence scenarios with TN in TDD mode (e.g. n34)

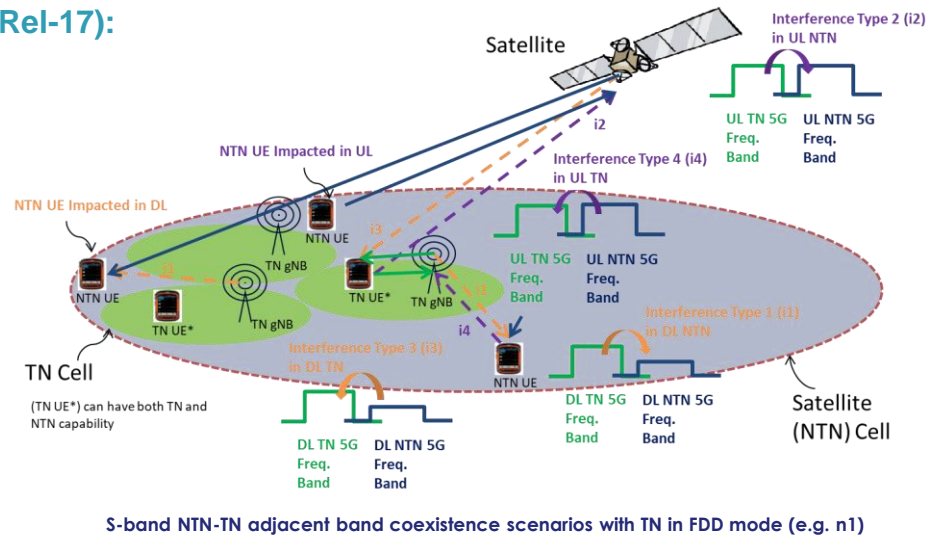

S-band NTN-TN adjacent band coexistence scenarios with TN in FDD mode (e.g. n1)

NTN-TN adjacent band coexistence analysis is essential for:

- Definition of RF core requirements;
- Introduction of new NTN bands.

5G NR NTN 3GPP bands in Rel-17 and Rel-18 (as for now)

“Exotic” Satellite frequency ranges compared with TN.

NTN operating bands in FR1 for satellite networks (FR1-NTN⁴)

NTN satellite operating band	UpLink (UL) operating band SAN receive / UE transmit $F_{UL,low} - F_{UL,high}$	DownLink (DL) operating band SAN transmit / UE receive $F_{DL,low} - F_{DL,high}$	Duplex mode
n256	1980 MHz – 2010 MHz	2170 MHz – 2200 MHz	FDD
n255	1626.5 MHz – 1660.5 MHz	1525 MHz – 1559 MHz	FDD

NOTE: NTN satellite bands are numbered in descending order from n256.

Rel-17

NTN operating bands in above 10 GHz for satellite networks (FR2-NTN⁵)

n512 ¹	27.5 - 30.0 GHz	17.3 - 20.2 GHz	FDD
n511 ²	28.35 - 30.0 GHz	17.3 - 20.2 GHz	FDD
n510 ³	27.5 - 28.35 GHz	17.3 - 20.2 GHz	FDD

NOTE 1: This band is applicable in the countries subject to CEPT ECC Decision(05)01 and ECC Decision (13)01.
NOTE 2: This band is applicable in the USA subject to FCC 47 CFR part 25.
NOTE 3: This band is applicable for Earth Station operations in the USA subject to FCC 47 CFR part 25. FCC rules currently do not include ESIM operations in this band (47 CFR 25.202).

Rel-18

Technical, regulatory & sometimes political challenges to introduce new bands.

Other release-independent Work Items will follow for other NTN band introductions..

[n254]	[1610 – 1626.5 MHz]	[2483.5 – 2500 MHz]	[FDD]
--------	---------------------	---------------------	-------

NOTE: NTN satellite bands are numbered in descending order from n256.

Rel-Independent

Difficult Satellite radio channel propagation, with relatively low Spectral Efficiency per end user.

FR1-NTN⁴: 410 MHz – 7125 MHz

FR2-NTN⁵: 17300 MHz – 30000 MHz

5G NR NTN Transmission Bandwidth Configuration (as for now)

Transmission bandwidth configuration N_{RB} for FR1-NTN

SCS (kHz)	5 MHz	10 MHz	15 MHz	20 MHz	30 MHz
	N_{RB}	N_{RB}	N_{RB}	N_{RB}	N_{RB}
15	25	52	79	106	160
30	11	24	38	51	78
60	N/A	11	18	24	38

SCS: Sub-Carrier Spacing

1 RB (Resource Block):
12 Sub-Carriers

Transmission bandwidth configuration N_{RB} for FR2-NTN

SCS (kHz)	50 MHz	100 MHz	200 MHz	400 MHz
	N_{RB}	N_{RB}	N_{RB}	N_{RB}
60	66	132	264	N/A
120	32	66	132	264

Take-Away

IRIS² (approach under construction):

Support implementation of **5G NTN standards** defined in 3GPP domain

- to the maximum extent possible and
- through a gradual implementation approach

Future roadmap, in order to support 5G/6G NTN-TN convergence:

- Satellite with **regenerative** payload: potentially starting from **Rel-19**;
- Evolution towards **6G New Radio**:
 - **Increasing Non-Terrestrial Network (NTN) capacity**:
 - Introducing **more Satellite frequency bands for increased capacity**;
 - **Integration of TN and NTN 5G/6G towards 3D (mesh) communications.**
 - **Simulation and testing capabilities**:
 - **6G WaveForm (WF) abstraction toolbox**;
 - **Channel Model** for satellite communication;
 - Evaluate **PAPR, resilience to Doppler & timing errors** of various WaveForms.

Some on-going work in 6G-NTN SNS R&D project.

6G-NTN SNS Project: Key Design Principles



6GNTN

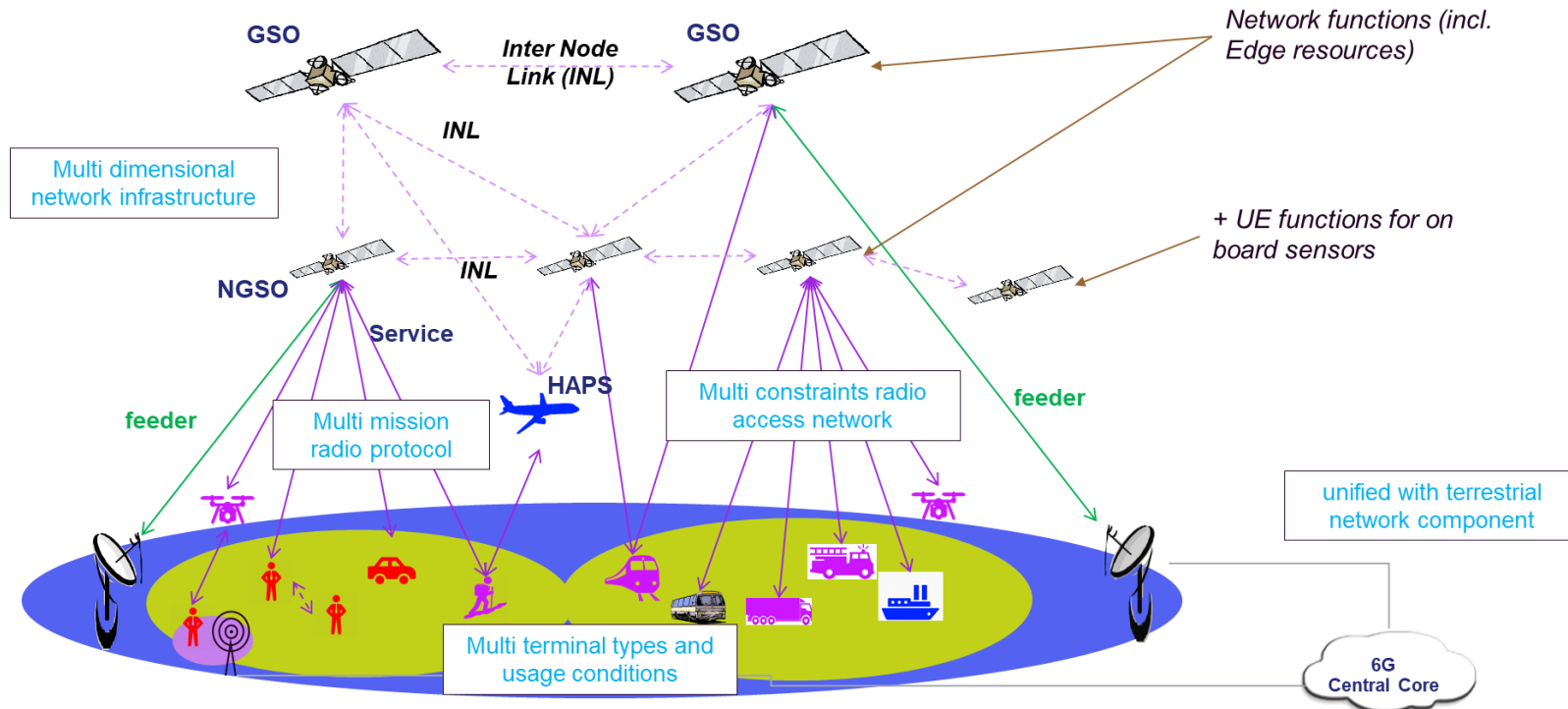

Ce document ne peut être reproduit, modifié, adapté, publié, traduit, d'une quelconque façon, en tout ou partie, ni divulgué à un tiers sans l'accord préalable et écrit de THALES - © 2021 THALES, Tous Droits réservés.

Any Questions?



Service Link Emulation & 6G WF Emulation – THALES SIX GTS FRANCE

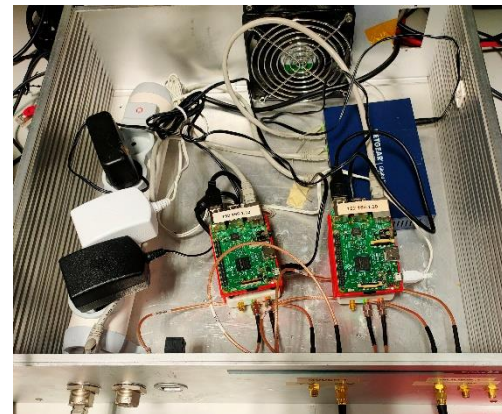
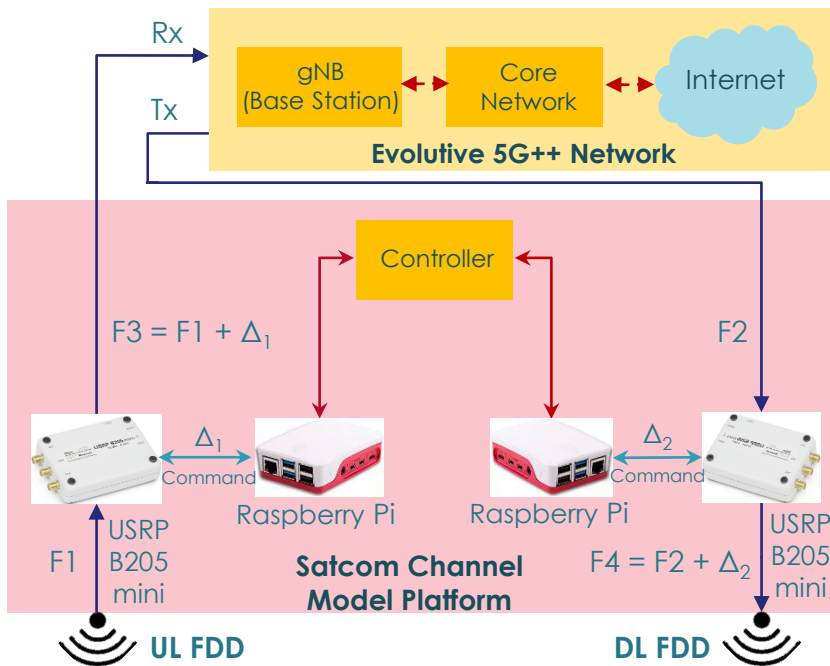

Satcom Channel Model Platform



Ce document ne peut être reproduit, modifié, adapté, publié, traduit, d'une quelconque façon, en tout ou partie, ni divulgué à un tiers sans l'accord préalable et écrit de THALES - © 2021 THALES, Tous Droits réservés.

Service Link Emulation & 6G WF Emulation – THALES SIX GTS FRANCE

- **NTN channel emulation of Doppler shift, attenuation, etc.**
- **5G NR Loss/Gain performance evaluation on NTN channel :**
 - **CP-OFDM WF** (5G New Radio Stand Alone), depending on synchronisation errors
- **6G WF Emulation :**
 - **OFDM based** : CP-OFDM, WOLA-OFDM, UF-OFDM, filtered OFDM, N-Cont. OFDM, BF-OFDM
 - **Non-OFDM based** : FMT, FBMC-OQAM, FBMC-QAM, FFT-FBMC, OTFS..
- **Evaluation of PHY layer resilience to Doppler shift and timing errors.**

Potential 6G WaveForm evaluation to be continued as part of 6G-NTN SNS Project

